

TK ピストンシール (NOK社:SPGN互換品)

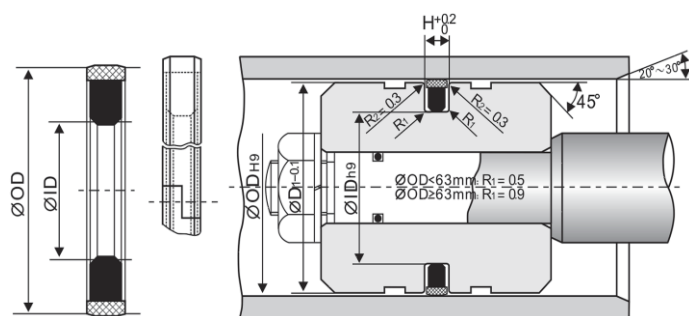

| 仕様 | |
|-----|------------------------|
| 材質 | NY+NBR |
| 温度域 | -35°C~110°C |
| 圧力 | 500kgf/cm ² |
| 速度 | 1m/s |

単位:mm

| 商品コード | 型番 | OD | ID | H | D1 |
|------------|---------------|-----|------|-----|-------|
| 1010-01280 | TK-063 | 63 | 47.5 | 6.3 | 62 |
| 1010-01300 | TK-070 | 70 | 52 | 7 | |
| 1010-01310 | TK-075 | 75 | 54 | 8 | |
| 1010-01320 | TK-080 | 80 | 59 | 8 | 79 |
| 1010-01325 | TK-085 | 85 | 64 | 8 | |
| 1010-01282 | TK-090-74.5 | 90 | 74.5 | 6.3 | 89 |
| 1010-01330 | TK-090-69 | 90 | 69 | 8 | 89 |
| 1010-01284 | TK-095-79.5 | 95 | 79.5 | 6.3 | 94 |
| 1010-01340 | TK-095-74 | 95 | 74 | 8 | 94 |
| 1010-01286 | TK-100-84.5 | 100 | 84.5 | 6.3 | 99 |
| 1010-01350 | TK-100-79 | 100 | 79 | 8 | 99 |
| 1010-01288 | TK-105-89.5 | 105 | 89.5 | 6.3 | 103.8 |
| 1010-01360 | TK-105-84 | 105 | 84 | 8 | 103.8 |
| 1010-01370 | TK-110 | 110 | 89 | 8 | 108.8 |
| 1010-01290 | TK-115-94-6.3 | 115 | 94 | 6.3 | 113.8 |
| 1010-01380 | TK-115-94-8 | 115 | 94 | 8 | 113.8 |
| 1010-01390 | TK-120 | 120 | 99 | 8 | 118.8 |
| 1010-01400 | TK-125 | 125 | 104 | 8 | 123.8 |
| 1010-01410 | TK-130 | 130 | 109 | 8 | 128.8 |
| 1010-01420 | TK-135 | 135 | 114 | 8 | 133.8 |
| 1010-01430 | TK-140 | 140 | 119 | 8 | 138.8 |
| 1010-01440 | TK-145 | 145 | 124 | 8 | 143.8 |
| 1010-01450 | TK-150 | 150 | 129 | 8 | 148.8 |
| 1010-01460 | TK-160 | 160 | 139 | 8 | 158.8 |
| 1010-01470 | TK-165 | 165 | 144 | 8 | 163.8 |
| 1010-01480 | TK-170 | 170 | 149 | 8 | 168.8 |
| 1010-01490 | TK-175 | 175 | 154 | 8 | 173.8 |
| 1010-01500 | TK-180 | 180 | 159 | 8 | 178.8 |
| 1010-01510 | TK-190 | 190 | 169 | 8 | 188.8 |
| 1010-01520 | TK-200 | 200 | 179 | 8 | 198.8 |
| 1010-01530 | TK-220 | 220 | 199 | 8 | 218.4 |
| 1010-01540 | TK-230 | 230 | 209 | 8 | 228.4 |
| 1010-01550 | TK-250 | 250 | 229 | 8 | 248.4 |